

RCI-18-23-002-1: R1 Suspension System Overview and Servicing Guidelines

Rivian LLC, Service Guideline

Document Type	Collision Repair Information Document
Date	February 6, 2023
Affected Region(s)	USA
Affected Model(s)	R1T, R1S
Model Year(s)	2022+
Vehicle System	18 - Suspension

Important:

- This procedure requires RiDE. Review the RiDE instructions specific to this procedure before starting work.
- Some RiDE routines are restricted and will need to be performed by a Rivian service center.

Attention:

- This document is intended as a general suspension system component overview and servicing guideline. Always refer to the Rivian service manual for vehicle specific information when servicing or replacing suspension components
- Rivian recommends that only Factory Certified Service Technicians inspect and repair the suspension system in Rivian vehicles. Please contact your regional Rivian Collision/Service Team to request more information, or for assistance with repairs.

General Information

To promote and maintain its rigorous standards of quality and safety, Rivian Automotive has issued this guideline to provide the collision industry with important information regarding the identification, inspection, and diagnosis of the various components that make up the suspension system of a Rivian vehicle.

Things to keep in mind,

- This document is a basic guideline to be used when inspecting the vehicle for damage to the suspension system, and its components, after a collision event.
- Proper set-up and function of the suspension system is vital for safety, comfort and for proper Advanced Driving Assistance System (ADAS) performance and functionality.
- Proper fill and bleed procedures must be carried out when servicing both the hydraulic system (Active Damper and Kinetic Roll Control) and air suspension system (Air Springs, Air Compressor). Refer to the service manual for the latest procedures.
- Rivian recommends that fill and bleed procedures be performed by a certified Rivian technician, using Rivian approved tools and fluids. Failure to do so may result in an unsafe driving condition and/or system/component malfunction.
- A wheel alignment may be required anytime a major suspension component is removed, replaced, or serviced. Refer to the service manual for more information.

Suspension System Component Location

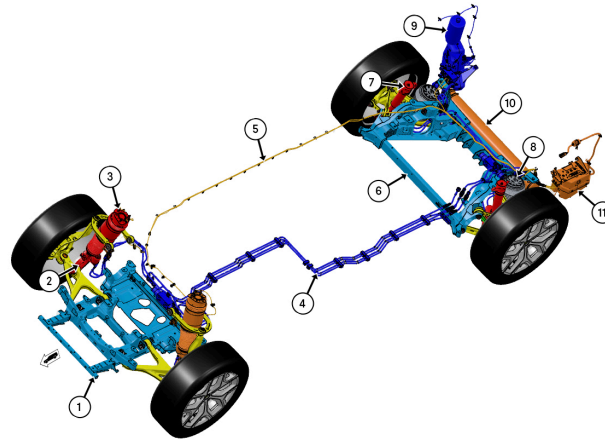

Number	Component
1	Subframe, Front
2	Active Damper, Front
3	Air Spring, Front
4	Hydraulic System Lines
5	Air Suspension System Lines
6	Subframe, Rear
7	Active Damper, Rear
8	Air Spring, Rear
9	Hydraulic Pump and Reservoir
10	Air Accumulator Tank
11	Air Compressor

Front and Rear Subframes

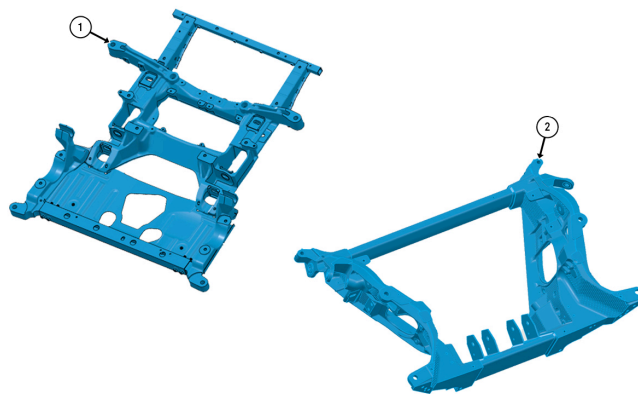

Number	Component
1	Subframe, Front
2	Subframe, Rear

- The front and rear subframes are constructed from aluminum.
- Major suspension components, steering components, modules, and hydraulic lines are attached to the front and rear subframes.
- After a collision event, visually inspect the subframes for cracks, tears, breaks, and bends.



Note: Closely inspect for possible cracks in welded areas of the subframe due to impact.

- Inspect the subframe using a tram gauge and a Rivian approved frame bench with subframe mounting points.
- Any damage to the front or rear subframes will require component replacement.



CAUTION: Repairs to the subframes are not allowed as this may compromise the safety of the vehicle and/or the occupants.

Front Suspension Components

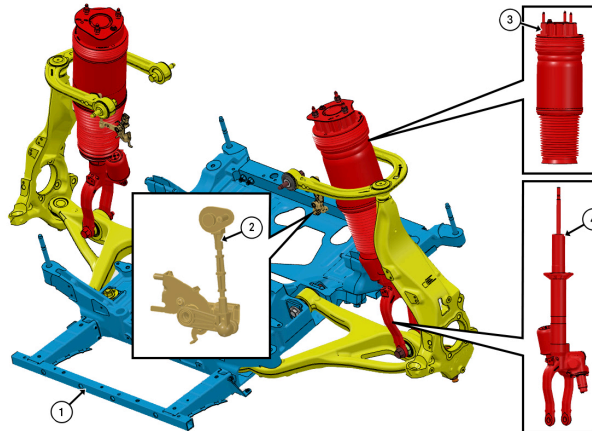

Number	Component
1	Subframe, Front
2	Ride Height Sensor, Front
3	Air Spring, Front
4	Active Damper, Front

- Rivian recommends that fill and bleed procedures be performed by a certified Rivian technician using Rivian approved tools and fluids.
- Suspension components are mostly constructed from Aluminum with steel mounting fasteners.
- Damaged suspension components are not repairable and must be replaced.
- Some of the mounting fasteners may be One-Time use only and must be replaced when servicing suspension components.



Note: Refer to the Fastener Reuse document when determining if bolt replacement is required.
[Fastener Reuse](#)

- Suspension components may require ride height level calibration after replacement or servicing.



Note: Refer to Rivian service documentation for details on suspension settings and calibration.

Rear Suspension Components

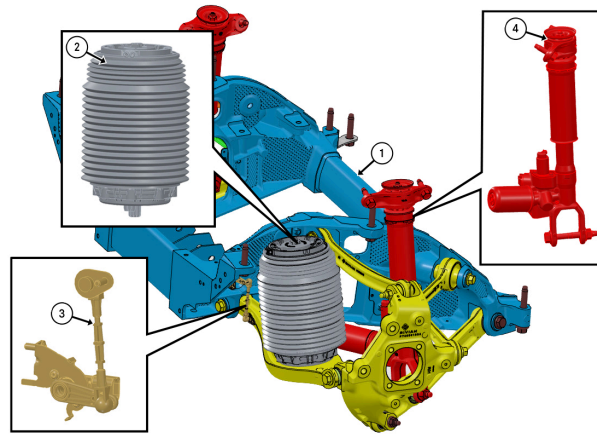

Number	Component
1	Subframe, Rear
2	Air Spring, Rear
3	Ride Height Sensor, Rear
4	Active Damper, Rear

- Rivian recommends that fill and bleed procedures be performed by a certified Rivian technician using Rivian approved tools and fluids.
- Suspension components are mostly constructed from Aluminum with steel mounting fasteners.
- Damaged suspension components are not repairable and must be replaced.
- Some of the mounting fasteners are One-Time use only and must be replaced when servicing suspension components.



Note: Refer to the Fastener Reuse document when determining if bolt replacement is required.
[Fastener Reuse](#)

- Suspension components may require ride height level calibration after replacement or servicing.



Note: Refer to Rivian service documentation for details on suspension settings and calibration.

Front Suspension - Air and Hydraulic System Line Connections

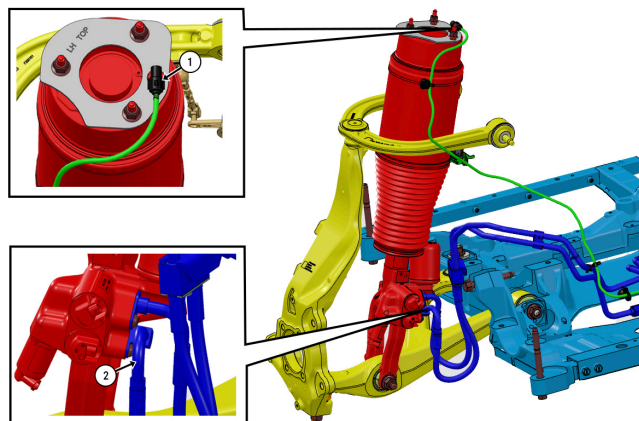

Number	Component
1	Air Line Connection
2	Hydraulic Line Connection

Rear Suspension - Air and Hydraulic System Line Connections

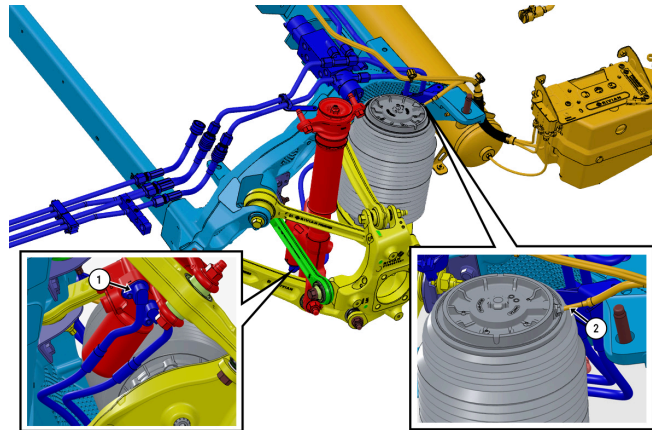

Number	Component
1	Hydraulic Connection
2	Air Line Connection

Air Suspension System - Line Inspection

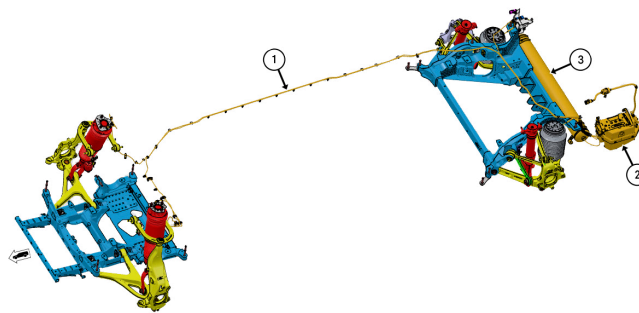

Number	Inspection Point	Inspect For	Action
1	Air Lines	Stress bends, cracks, fluid leaks from threaded fittings using soapy water	Air lines are only serviceable at the end connection points with approved Rivian fittings
2	Air Compressor	Broken mounting brackets, abnormal noises during operation of air suspension, damaged intake, or breather hoses	Replace if damaged
3	Air Accumulator Tank	Mounting bracket welds, proper pressure holding, air leaks	



Note: The Air suspension sets the vehicle ride height and has no relation to the damping or roll control of the vehicle.

Hydraulic Active Damper System - Line Inspection

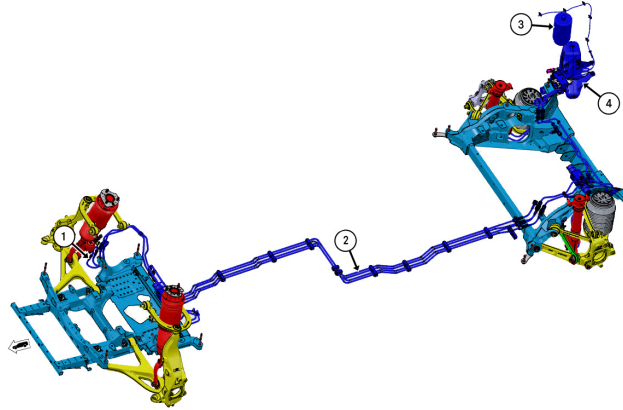

Number	Inspection Point	Inspect For	Action
1	Flexible Lines	Rubbing, tears, surface bulging, fluid leaks at connection points	Air lines are only serviceable at the end connection points with approved Rivian fittings
2	Hard Lines	Kinks, tears, dents, abnormal bends	Hard lines are not serviceable and must be replaced
3	Reservoir	Broken mounting brackets, fluid leaks	Replace if damaged
4	Pump	Abnormal noises during operation, damaged breather hose	